



# Tom Norton - RTE Radio Production Engineer

EBU Discussion:

Achieving a Good Sound Balance When Working Multiplatform

09/06/2021



# RTE NSO from the National Concert Hall

## 28/05/2021

- This concert was broadcast live on RTE Lyric FM and Lyric FM's Youtube channel.
- It was subsequently broadcast on our RTE 1 TV station
- The program was:
  - Mahler Adagietto from Symphony 5.
  - Korngold Einfache Lieder
  - Mendelssohn Symphony No.1
- Tara Erraught (mezzo-soprano)
- Jaime Martin (conductor)
- RTÉ National Symphony Orchestra
- Paul Herriott (presenter)

# Orchestra Layout and micing:

RTE National Symphony Orchestra – NCH 28/05/2021

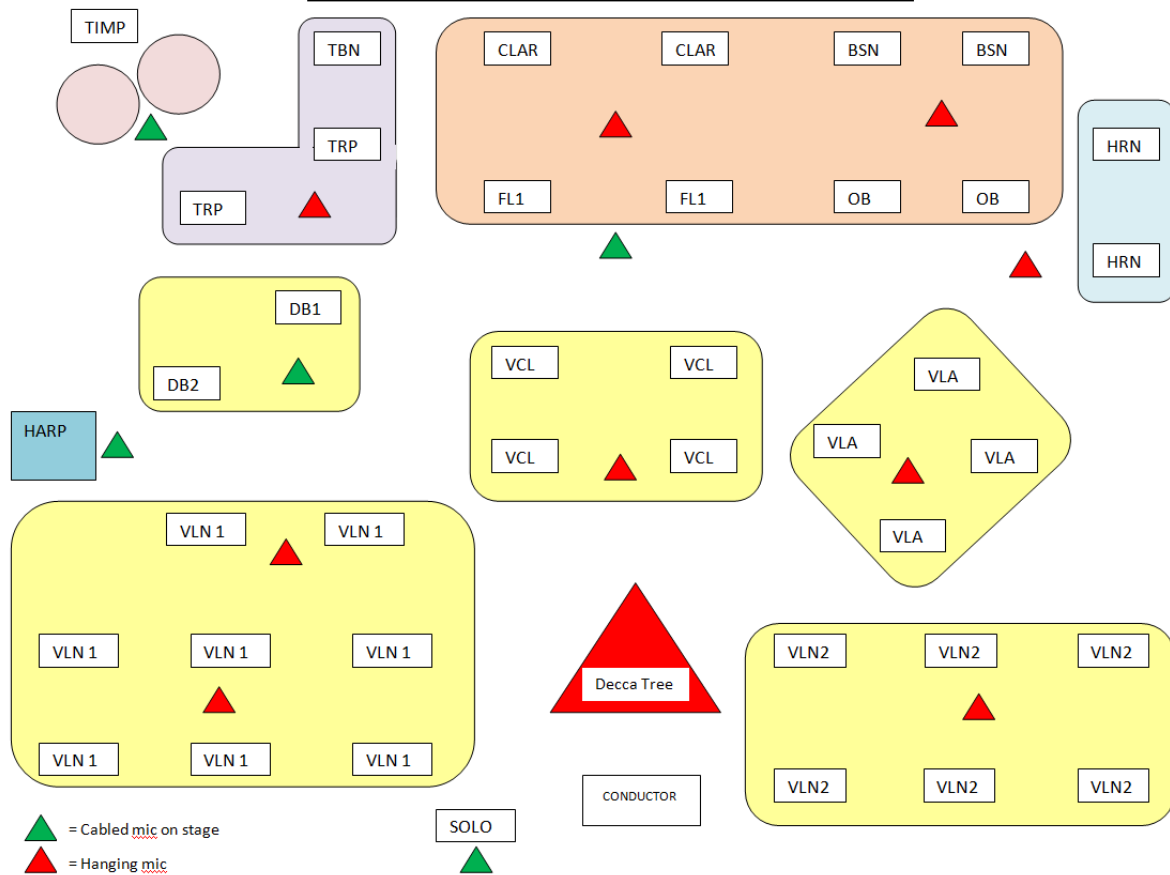

# Channel List

Channel	Microphone	Section/Instrument	Stage/Hanging
1	DPA 4036	Violin 1 Wide Left	Hanging
2	DPA 4036	Decca L	Hanging
3	DPA 4036	Decca C	Hanging
4	DPA 4036	Decca R	Hanging
5	DPA 4036	Violin 2 Wide Right	Hanging
6	DPA 4036	Violin 1	Hanging
7	DPA 4036	Cello	Hanging
8	DPA 4036	Viola	Hanging
9	Neumann U87	Double Bass	Stage
10	DPA 4022	Brass	Hanging
11	DPA 4022	Clarinet	Hanging
12	DPA 4022	Bassoon	Hanging
13	DPA 4022	Oboe/Horn	Hanging
14	DPA 4006	Flute	Stage
15	Neumann 184	Harp	Stage
16	Sennheiser MKH40	Timpani	Stage
17	DPA 4006	Soloist	Stage
18	Shure 87A	Conductor	Radio

# Work Process – Pre TX:

- We provide two stereo mixes of our output to the Video Streaming Room. One is for the Youtube feed and one is for the transmission record for the Sunday morning TV broadcast.
- The feed for Youtube is a matrix mix of the stereo output and has 4dB added.
- The other feed is lined up with 0dBu tone at -18dBFS.
- Both feeds are delayed by 80mS to sync the audio with vision.
- The introductions to each piece are recorded earlier in the day. This VT is played in live during the concert at the start, before each piece and at the end.
- We take a feed of this audio from the VT playback for our TX and provide it back to the Streaming Room via our output.
- All line-ups between Sound, Vision and our Master Control are carried out at 2PM with second line-up carried out at 6pm.

# Work process - TX:

- We send an Off Air feed of Lyric FM to the Streaming Room.
- Our output is put to air from our Lyric Studio in Limerick by a Studio Coordinator.
- All cues will have been discussed beforehand.
- We output some low level room atmos in the five minutes leading up to TX. This is for the live stream
- Lyric is scheduled to play an introductory jingle at exactly 7pm.

# Work process – TX continued:

- We have talkback between Radio, vision and the side of stage.
- The Off Air feed is also sent to speakers at the side of stage.
- We each have scripts to follow.
- As the introductory VT concludes we will receive a 30 second and 10 second cue/countdown to the end of the VT.
- The orchestra manager will cue the Maestro to go on stage and the concert begins

# Work process - TX continued:

- After each piece, a VT package is played in. This audio comes to us on an audio tieline from the Streaming Room and we put the audio to air.
- We receive a 30 second and 10 second cue and countdown to the end of the VT via talkback.
- The soloist is cued to go onstage by the Orchestra Manager who has the same Off Air, talkback feeds and script.





# Work process - TX continued:

- At the end of the concert our Radio TX is faded down in Limerick and they rejoin their studio programs.
- We leave room atmos on our desk as the credits play out over the video stream.

# TX Audio Signal Paths

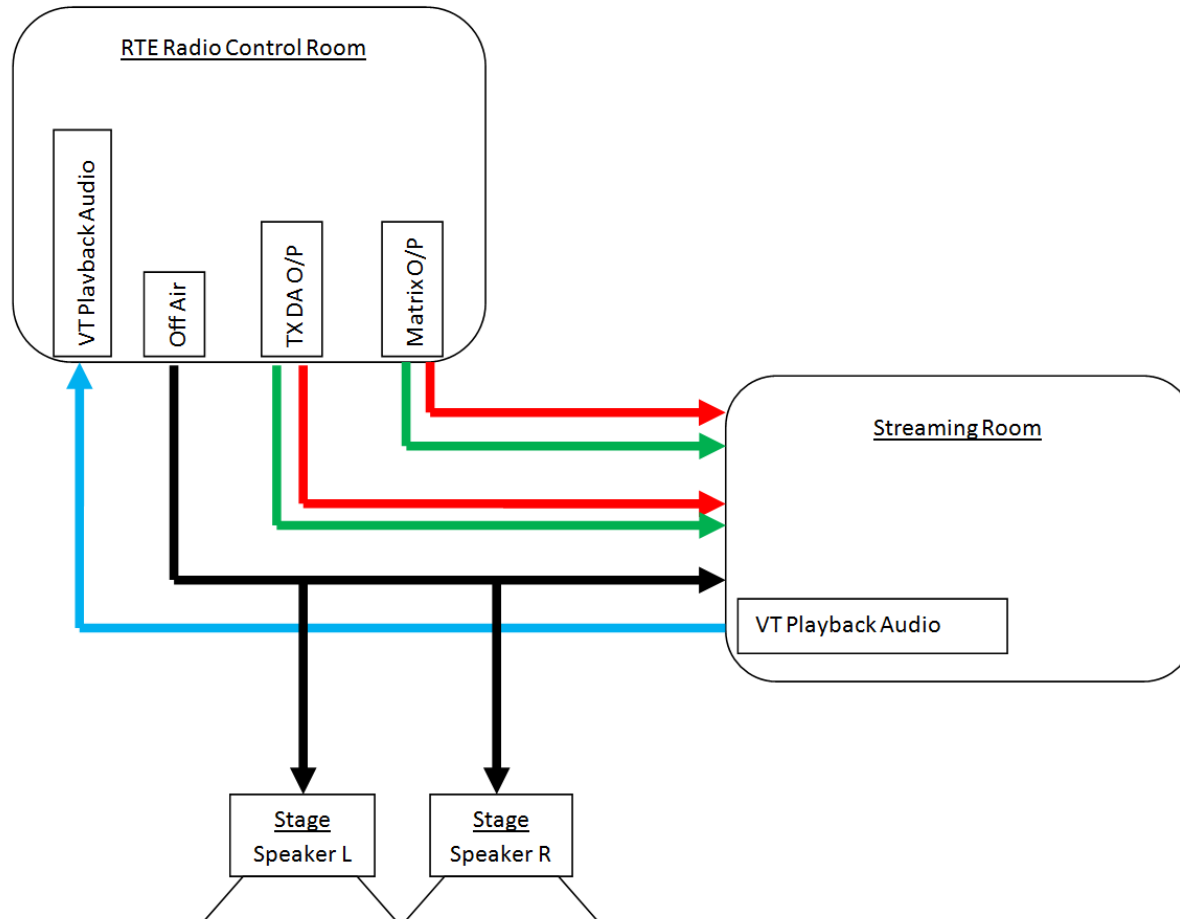

# Photos

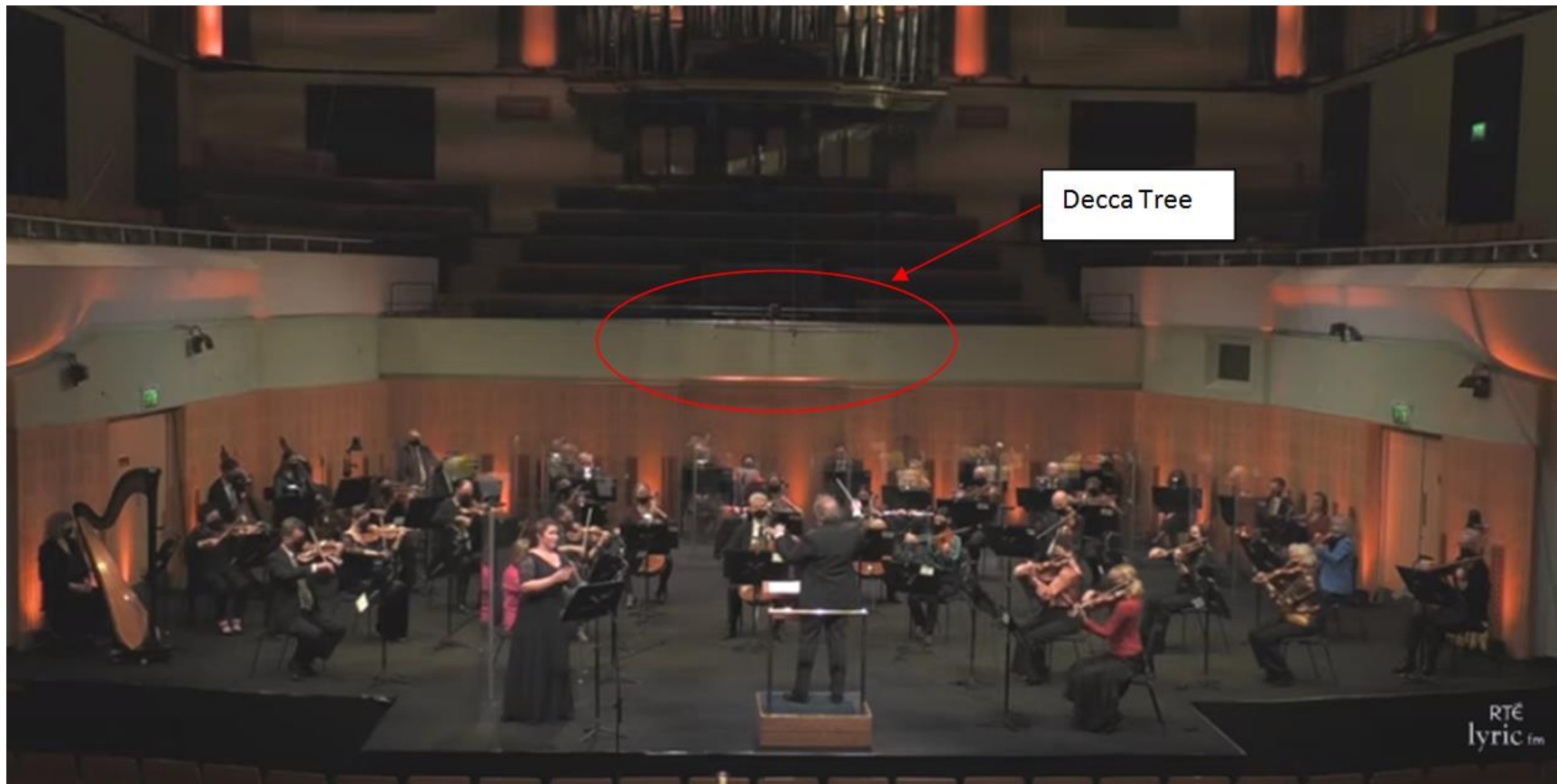

# Photos



Soloist's mic

# Photos

